



**REVERSE OSMOSIS SYSTEM**  
**Installation, Operation & Maintenance Manual**  
**EC 4-Stage RO System**



**IMPORTANT**

Please read this manual carefully before proceeding with installation or maintenance. All work must be conducted by a trained water treatment professional, familiar with the equipment. Failure to follow instructions or operating parameters, may lead to personal injury or damage to the equipment and/or personal property. The information provided in this document is solely for informative purposes. It is the user's responsibility to ensure the appropriate installation, usage, and maintenance of all equipment.

Do not use this system with water from non-potable water sources, microbiologically unsafe water, or water of unknown quality without adequate disinfection before and after the system. Feed water parameters must always be followed.

All RO systems contain replaceable water treatment components critical for effective performance. It is the user's responsibility to regularly inspect the system and test the product water to verify satisfactory performance. All components should be replaced at the Manufacturer's recommended time, or when the component shows signs of needing replacement, whichever occurs first. A leak detection and supply water shutoff device must always be installed and operational. Failure to take necessary precautions and properly maintain this RO system may cause a health risk, lead to personal injury, and/or cause damage to the equipment and personal property.

To maintain the manufacturer's warranty, an operating log must be maintained and copies will need to be sent to your local dealer or distributor for review.

Save this manual for future reference.

**Please fill out the following information at the time of installation.  
This information may be important for future reference.**

Model: \_\_\_\_\_  
Serial Number: \_\_\_\_\_  
Install Date: \_\_\_\_\_  
Sold By: \_\_\_\_\_  
Installed By: \_\_\_\_\_  
Service Phone Number: \_\_\_\_\_

This Manual is for the Following Models:

**90403** – Jaco Style Model

*90514, 90507, 90515*

**90404** – John Guest Style Model

*90516, 90504, 90517*

# Table of Contents

Section 1: Introduction.....	3
Section 2: Important Background Information .....	4
What is Reverse Osmosis (RO).....	4
How the Reo-Pure™ RO System Works .....	4
Importance of Pre-Filtration .....	4
Automatic Shut-Off Technology.....	4
Factors That Affect System Performance .....	4
How to Make a Proper Quick-Connect Tubing Connection.....	5
How to Make a Proper Compression Nut Tubing Connection.....	5
Section 3: System Specifications .....	7
Design Specifications.....	7
Feed Water Parameters .....	7
Section 4: Getting to Know Your System .....	8
Section 5: Flow Diagram.....	10
Section 6: Installation Instructions.....	10
What You'll Need.....	11
What's Included.....	11
Step 1: Select an Installation Site.....	12
Step 2: Faucet Installation .....	12
Step 3: Install Valve to Feed Water Supply.....	13
Step 4: Install the Drain Saddle Clamp .....	15
Step 5: Install the Tank Shut-Off Valve.....	15
Step 6: Install the RO Membrane.....	16
Step 7: Install the Filter Cartridges.....	17
Step 8: Mount RO System.....	17
Step 9: Make Tubing Connections.....	17
Step 10: Ice Maker Connection (Optional).....	20
Step 11: Record Information in a System Maintenance & Repair Log .....	20
APPENDIX: Basement Installations .....	21
Section 7: Start-Up Procedure .....	23
Section 8: Maintenance Procedures.....	24
Filter Cartridge and RO Membrane Replacement .....	24
Replacing Filter Cartridges.....	24
Changing the RO Membrane .....	25
Sanitize the RO System and Storage Tank .....	26
Section 9: RO Service Record Information .....	27
Section 10: System Troubleshooting .....	28
Section 11: Product Warranty.....	30
Section 12: Replacement Parts List .....	32

## Section 1: Introduction

**Thank you for choosing this Reverse Osmosis Drinking Water System!** Every Reo-Pure™ RO System incorporates years of experienced engineering, dedicated workmanship, and high-quality components. Each system is built with pride and ensures superior performance. We are confident you will find this system to have quick and simple installation, hassle-free maintenance, and years of reliable, trouble-free operation.

Proper installation and maintenance of your new RO System is very important. Please read and follow this instruction manual carefully before attempting installation. Failure to do so could result in personal injury or damage to the equipment and/or personal property. As with all products, the customer has the responsibility to ensure that the RO System is operated under proper conditions and within design limitations.

**IMPORTANT:** Improperly installed systems could result in water damage due to leaks or flooding. System installation must also always comply with local and state laws and regulations. Proper installation of this system requires familiarity with state and local codes, standard sink plumbing, and proper use of the necessary tools. If you are not familiar with any of these, or have difficulty with the installation of this system, please contact an experienced water treatment professional to perform the installation.

## Section 2: Important Background Information

### What is Reverse Osmosis (RO)

In the reverse osmosis process, water is forced under pressure through a semi-permeable membrane to reduce the dissolved mineral content of the water. The membrane allows water molecules to pass through, but blocks/hinders the passage of dissolved substances and suspended particles. This process reduces the levels of dissolved salts, minerals, and suspended particles, while improving the taste, odor, and clarity of the water.

Certain contaminants found in water are measured as Total Dissolved Solids (TDS). Unlike the more common standard filtration systems, reverse osmosis systems divide the feed water into two streams: product water (“permeate”) and drain/reject water (“concentrate”). The product water is the desired outcome of the RO System – much cleaner and fresher tasting water! The drain/reject water is vital for carrying away the dissolved salts, minerals, and suspended particles. Unlike conventional filtration systems, the majority of contaminants removed from your water are not held onto within the system, but instead flushed away.

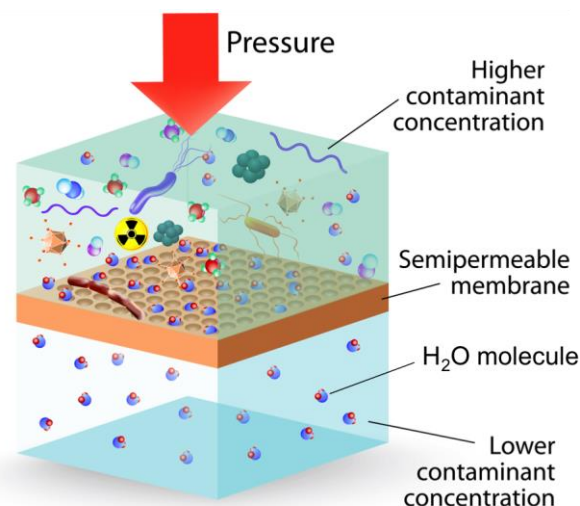

### How the Reo-Pure™ RO System Works

Your new Reo-Pure™ RO System uses a combination of filtration technologies to reduce unwanted contaminants in a water supply. The model you have chosen incorporates a series of stages to give you the most out of your RO System! For more information on your unique model, please refer to the “Getting to Know Your System” section to better understand the different stages that work together in making your RO System great!

### Importance of Pre-Filtration

Pre-treatment in a RO System is crucial. By running the feed water through the appropriate pre-filter, the RO membrane is protected against permanent premature fouling damage. The filter cartridges in this system must be replaced on a regular basis to maintain efficiency and to ensure high water quality. Any significant change in performance of the system should be investigated promptly to avoid secondary damage or deterioration to other parts of the system.

### Automatic Shut-Off Technology

Every RO System comes equipped with an automatic shut-off valve. This component closes when it senses that the storage tank is full – immediately shutting off the water supply. As a result, the production of water is paused, and excess reject water is prevented from draining.

### Factors That Affect System Performance

**Feed Water Temperature:** The ideal water temperature for a RO System is 77°F. The quantity of product water produced increases with higher water temperatures and decreases with lower water temperatures. Temperatures below 40°F can damage the membrane, and temperatures above 90°F can cause rapid deterioration of the membrane.

**Feed Water Pressure:** The greater the water pressure, the better water quantity and quality the system will produce. Water pressure of 65 psi is ideal.

**Total Dissolved Solids (TDS):** The higher the amount of dissolved contaminants in the feed water, the lower the quantity of water produced. A high level of TDS can be overcome with a booster pump.

**Bacteria:** When RO Systems are used, tested, or operated intermittently, they may be exposed to bacteria. Following a shut down or storage period, the RO System and storage tank should be sanitized.

**Fouling or Surface Coating of the Membrane:** Membrane fouling is a common problem resulting from salts, hardness, iron, etc. collecting on the membrane surface. The pores and channels of the membrane become plugged, reducing the water production rate. Pre-treatment equipment, such as a water softener, iron filter, and/or turbidity filter, will reduce membrane fouling and extend its life.

## How to Make a Proper Quick-Connect Tubing Connection

If you have the **EC-John Guest** model, then your RO System has been designed with the most reliable quick-connect fittings available (see next section for information on compression nut fittings). It is important that the manufacturer's instructions are followed carefully to ensure a leak-free connection.

To make a connection, the tube is simply pushed in by hand; the unique patented John Guest collet locking system then holds the tube firmly in place without deforming it or restricting flow.



### CUT THE TUBE SQUARE



Cut the tube square and remove burrs and sharp edges. Ensure that the outside diameter is free from score marks. For soft or thin-walled plastic tubing we recommend the use of a tube insert.

### PUSH UP TO TUBE STOP



Push the tube into the fitting and up to the tube stop.

### TO DISCONNECT Push in collet and remove tube

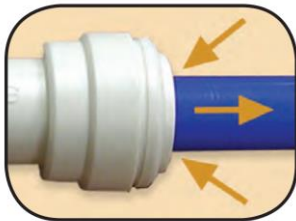

To disconnect, ensure that the system is depressurized, push the collet square against the fitting. With the collet held in this position the tube can be removed.

### PULL TO CHECK SECURE



Pull on the tube to check that it is secure. Test the system before use.

## How to Make a Proper Compression Nut Tubing Connection

If you have the **EC-Jaco** model, then your RO System has been designed with the most reliable compression nut fittings available (see previous section for information on quick-connect fittings). It is important that the manufacturer's instructions are followed carefully to ensure a leak-free connection.

Always make sure to cut tubing ends square. The cut end must be free of burrs and sharp edges. For soft thin walled plastic tubing, we recommend the use of a tube stop/insert.

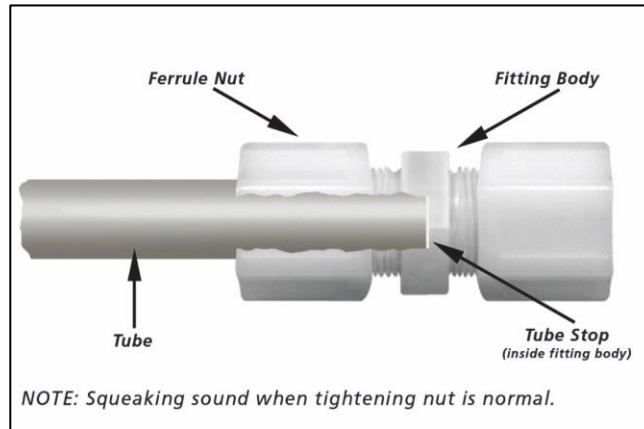

- 1) Press tube stop/insert into inside end of tubing.
- 2) Insert the tubing through the back of the nut all the way through the nut assembly to the tube stop in the fitting body. If the tubing does not enter the nut easily, loosen the nut one turn and then insert the tubing all the way to the tube stop.
- 3) Turn the nut hand tight.
- 4) Wrench tighten the nut 1-1/2 to 2 turns.
- 5) All nuts must be retightened when the system reaches projected operating temperature.

**NOTE:** It is not necessary to fully remove the fitting nut for application. Merely loosen the nut enough to insert tubing all the way into tube stop and tighten nut.

## Section 3: System Specifications

### Design Specifications

Production:	RE-1812-25 – 25 GPD*
	RE-1812-50 – 50 GPD*
	RE-2012-100 – 100 GPD*
	RE-2012-LP – 150 GPD*
Rejection (NaCl):	96-98%
Recovery:	25%
Feed TDS:	200 mg/L NaCl
Feed Pressure:	65 psi
Feed Temperature:	77°F (25°C)
Feed pH:	6.5-7.0

*\*Actual system production may vary depending on incoming water temperature and chemistry. Permeate flow rate for each element may vary but will be no more than 15%.*

### Feed Water Parameters

Temperature:	Max 90°F (37.8°C), Min 40°F (4.4°C)
Pressure:	Max 80 psi, Min 45 psi
Iron:	Max 0.5 ppm
Hardness:	Max 10 gpg, or 170 mg/l
Chlorine:	< 0.1 mg/L.
Total Dissolved Solids (TDS):	Max 1,000 ppm
Turbidity:	Less than 1.0 NTU
pH:	3.0-11.0 (optimum rejection at 6.5 – 7.0)
Manganese:	Max 0.05 ppm
Hydrogen Sulfide:	0.00
Bacteria:	Feed water must be potable.

**Note:** The water pressure in your home should be tested over an extended period to attain an accurate pressure reading. If possible for water pressure to exceed 85 psi, a pressure regulating device must be used. If the water pressure falls below 45 psi, a booster pump may be required. A feed water pressure below 45 psi will severely lower the efficiency of your RO System, and may inhibit the automatic shutoff from properly closing.

**Note:** The system will operate with hardness over 10 grains, but the RO membrane life may be shortened. The addition of a water softener will extend the life of the RO membrane.

**IMPORTANT:** Do not use this system with water that is microbiologically unsafe or of unknown quality without adequate disinfection before or after the system.



# Section 4: Getting to Know Your System

It is important to familiarize yourself with your new Reverse Osmosis System.

Shown below is a front and top view of your Reo-Pure™ RO System. The stages and main components identified. These components will be referenced throughout the manual. Noting their location will assist you with the installation and maintenance of the RO System.

TOP VIEW

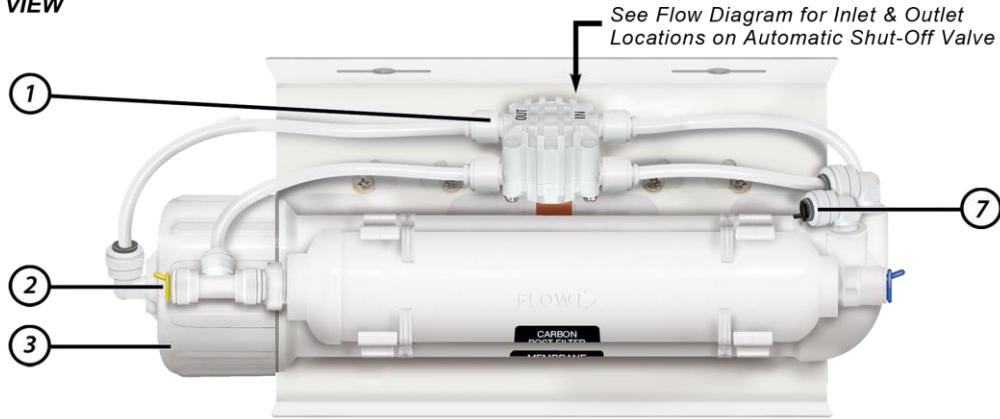

FRONT VIEW

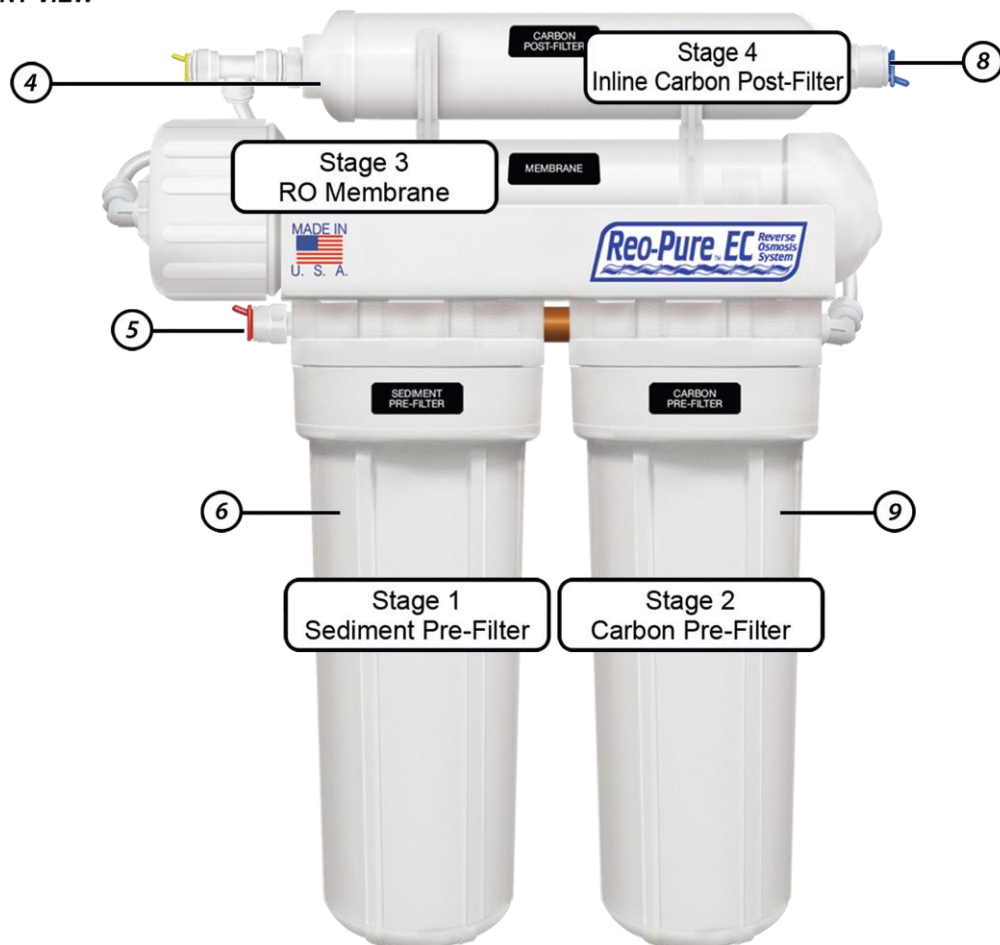

- |   |  |
|---|--|
| 1. Automatic Shut-Off Valve               | 6. Sediment Pre-Filter Housing             |
| 2. Storage Tank Outlet (3/8" Yellow Plug) | 7. Drain / Reject Outlet (1/4" Black Plug) |
| 3. RO Membrane                            | 8. Product Water Outlet (3/8" Blue Plug)   |
| 4. Inline Carbon Post Filter              | 9. Carbon Pre-Filter Housing               |
| 5. Feed Water Inlet (1/4" Red Plug)       |  |

## Stages of Filtration

Get to know the stages of filtration your water is going through. Below is a visual representation of each stage on your Reo-Pure™ RO System.



STAGE	DESCRIPTION	REPLACE
Stage 1	<b>Sediment Filter</b> 5-micron, 2.5" x 9-7/8"	Every 3-6 Months
Stage 2	<b>Carbon Block Filter</b> 10-micron, 2.5" x 9-7/8"	Every 3-6 Months
Stage 3	<b>RO Membrane</b> Up to 98.0% Rejection, 1.8" x 12"	Every 2-4 Years
Stage 4	<b>Alkaline Post Filter</b> Inline Alkaline Filter 2.5" x 12"	Every 1 Year or 2,000 gal

# Section 5: Flow Diagram

The actual flow diagram of every EC Series RO System may slightly vary based on the number and types of stages. However, the general concept of the feed water being pre-treated and split into two streams (Product and Reject) after the membrane is consistent with every model.

Provided below is a detailed flow diagram for your Reo-Pure™ RO System. Please take the time to familiarize yourself with the placement of major components and the correct flow of water through them. Understanding this will be very important for the installation and maintenance of your RO System. It is also recommended to reference this diagram again when making your tubing connections. This will ensure proper identification and placement of connections.

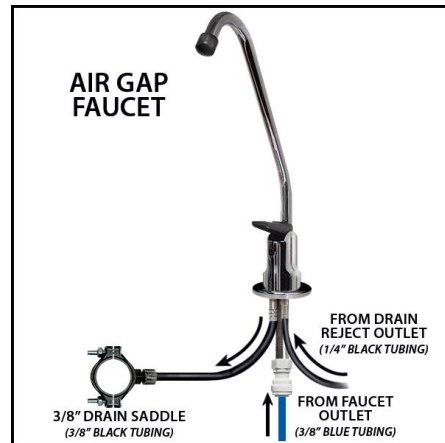
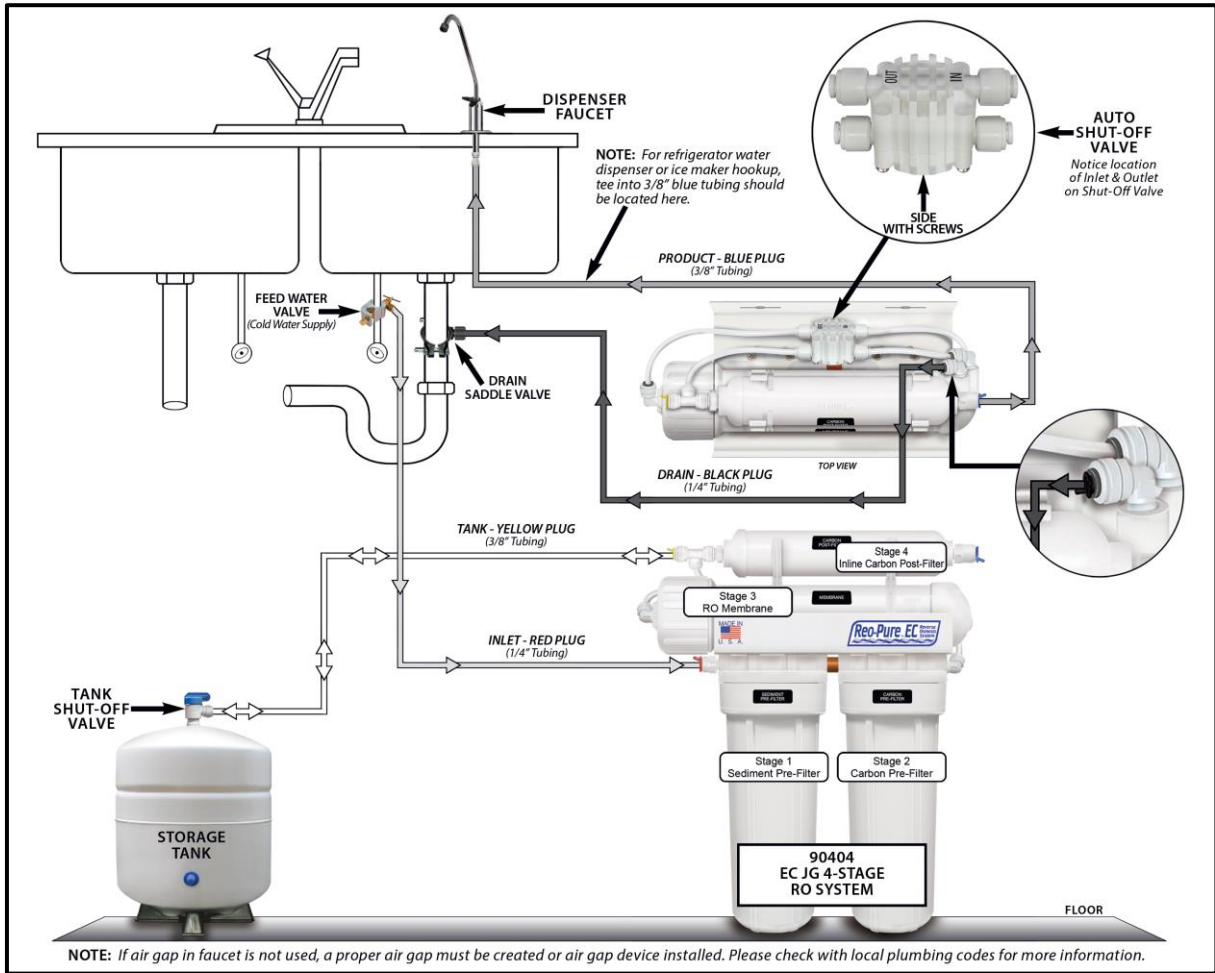





















## Section 6: Installation Instructions

### What You'll Need

- ✓ Extension work-light
- ✓ Battery operated drill and drill bits
- ✓ 1-1/4" Hole saw bit/punch for faucet
- ✓ Screw Drivers (Phillips & flathead)
- ✓ Pliers (needle nose & adjustable)
- ✓ Utility Knife
- ✓ Tubing Cutter
- ✓ Teflon Tape
- ✓ Safety Glasses
- ✓ Food Grade Lubricant
- ✓ TDS Test Meter

### What's Included

MAJOR COMPONENTS			
 Reo-Pure™ RO System	 Sediment Filter Cartridge Qty: 1	 Carbon Filter Cartridge Qty: 1	 Carbon Filter Inline Qty: 1
 RO Membrane*	 Dispenser Faucet*	 Storage Tank*	

PARTS PACKET			
 Tank Shut-Off Valve	 Faucet Connector	 Filter Housing Wrench	 1/4" & 3/8" Tube Insert
 Self-Piercing Saddle Valve <b>(Optional)*</b>	 Drain Saddle Clamp*	 1/4" Red Tubing	 3/8" Blue Tubing
 John Guest® Angle Stop Adapter Valve <b>(Optional)*</b>	 Capillary Drain Flow Restrictor*	 1/4" Black Tubing	 3/8" Yellow Tubing
 Mur-lok® RO-Pal Connector <b>(Optional)*</b>			

**NOTE:** If an air gap faucet is not used, reject water must go to drain through an anti-siphon air gap. Please check local plumbing codes.

\*Based on order customization, parts may not be included.

## Step 1: Select an Installation Site

This RO System was designed compact enough to fit under most kitchen sinks. However, the RO System may easily be installed in a basement, closet, crawl space, or wherever it's most convenient. If a basement installation is selected, note that additional tubing, hardware, and fittings may be needed, and that a hole must be made from inside the cabinet through the floor to the basement.

When determining the best location to mount the RO System, there must be access to a cold water line and a drain line. Never install in an area of the home where temperature is freezing as it may result in damage to the system. The water storage tank may weigh over 35 pounds with a 4 gallon tank, when full of water. Be sure to place it on a firm, level surface.

The exact placement of the RO System and its accessories will vary with each installation. The installer and customer must coordinate together on determining the most convenient placement of the dispenser faucet, RO System, and storage tank.

Always consider easy maintenance and servicing when choosing an installation site. It's recommended to mount the RO System at least 4" off the ground. This will allow ample room to remove the filter housings. However, if the mounting wall is not solid, the system may sit on the floor with screws used to keep it against the cabinet/wall in a vertical position.

Consideration for an ice maker or additional connections should also be made at this time. Extra routing, tools, fittings, and tubing may be required.

**IMPORTANT:** For basement installations, please see the **APPENDIX** at the end of this section for additional information.

## Step 2: Faucet Installation

When selecting a location for your faucet, be sure the stem of the faucet will be accessible for making all connections. Always take special care and consideration if drilling a new hole for a faucet. We cannot accept any responsibility for damage to sinks or countertops when you are drilling a hole for your dispenser faucet. The following are only guidelines to aid with the installation for your dispenser faucet.

Under the counter installations generally require that the faucet be installed with the air gap module. In basement installations, the air gap module can be eliminated only if one is provided elsewhere in the drain line.

**NOTE:** The Uniform Plumbing Code dictates that there must be an air gap between the RO line and the waste drain. It is the responsibility of the installer to ensure compliance with all State and Local laws and regulations

**IMPORTANT:** For basement installations, please see the **APPENDIX** at the end of this section for additional information.

### Drill Hole for Faucet

Most sinks are predrilled with a hole that's commonly used for a sprayer or soap dispenser. This could be used for a RO faucet instead, with no need to drill a new one. However, if your installation site does not have a properly sized hole, or it's already being used, an additional hole will need to be drilled. Always check below the sink to make sure nothing will interfere when drilling, and that a 2" flat surface is available on your sink for mounting the faucet. The faucet should be aesthetically located, positioned to flow directly into the sink, and able to swivel freely for convenience.

#### *Drilling a Stainless Steel Sink*

The faucet opening should be centered between the back splash and the edge of the sink, ideally on the same side as the vertical drainpipe.

- 1) Mark the center and drill a 1/4" pilot hole.
- 2) Continue to enlarge hole with increasingly larger drill bits until the hole is 1/2" in diameter.
- 3) Smooth any rough edges and sweep away chips.

**Note:** Air Gap faucets require a 7/8" hole.

#### *Drilling a Porcelain Sink*

Porcelain sinks are extremely hard and can crack or chip easily. Always use proper tools and extreme caution when drilling.

- 1) Place a piece of masking tape over the area to be drilled to help avoid chipping.
- 2) Mark the center of the hole on the tape.

- 3) Drill a pilot hole using 1/4" carbide tipped pilot drill bit.
- 4) Drill at a slow speed to avoid cracking and chipping.
- 5) Using a porcelain cutter, drill out 1/2" hole. Keep the drill speed on the slowest speed and use lubricating oil to keep the drill bit cool.

**Note:** Air Gap faucets require a 7/8" hole.

- 6) Remove all sharp edges with a file.
- 7) Make sure the surroundings of the sink are cooled before mounting the faucet.

#### Mount the Faucet

- 1) Slide the 1-1/4" faceplate, rubber washer, and the 1-7/8" rubber gasket onto the faucet stem.
- 2) Place the stud through the hole in the sink or counter top, and properly position the faucet.
- 3) From under the counter, slide on the black plastic washer and the metal star washer, and screw on the faucet lock nut.
- 4) Tighten securely.
- 5) At the bottom of the faucet stem, securely tighten the John Guest® faucet connector (provided in the Parts Packet with your system).

**Note:** Any remaining faucet parts are replaced by the John Guest® faucet connector and can be discarded.



#### Step 3: Install Valve to Feed Water Supply

Locate the cold water supply shut-off valve, and turn it off. Open the cold water sink faucet to release any water and pressure. On single handled faucets, the hot water may have to be turned off to prevent any hot water crossover. If water continues to come out of the faucet, with the valve turned off, the main house line may need to be turned off.

The following instructions describe the installation of three different types of valves that can be used on a feed water supply line. Please take note of which valve you are using, follow those instructions carefully, and skip the step details for the other valve options.

**CAUTION:** Do not connect the feed water valve to the hot water pipe. Hot water will severely damage your RO membrane. The connection must be made with the cold water line.

#### If Using John Guest® Angle Stop Adapter Valve (Optional)



The John Guest® Angle Stop Adapter Valve has been designed to easily tap into the cold water supply, right in between the cold water supply valve and the existing riser faucet line. Installation is fast and easy, without the need to pierce the feed line.

- 1) Be sure the water supply is off.
- 2) Disconnect the riser from the brass/chrome cold water supply valve.
- 3) Visually inspect the angle stop adapter valve to ensure that the sealing gasket is properly seated in the female threads.
- 4) Screw and securely tighten the angle stop adapter valve to the cold water supply valve.
- 5) Screw and securely tighten the riser to the angle stop adapter valve.
- 6) Leave the valve closed at this time.



### If Using C-Style Self-Piercing Saddle Valve (Optional)



The C-Style Self-Piercing Saddle Valve is a great option for copper piping, but can also be used with hard steel, iron, brass, or CPVC piping. The simple mechanism fits 3/8" and 5/8" copper tubing. When the hand crank is turned, its ease-of-use technology pierces the cold feed water pipe. This opens the feed water line to its 1/4" compression nut connection. Self-Piercing mechanism is not intended for flex line tubing.

#### Installing on Soft Copper Pipe

- 1) Be sure the water supply is off.
- 2) Turn the valve handle counter clockwise until the lance (sharp point) does not protrude from the black gasket.
- 3) Position the valve around the cold water supply line (copper pipe) and insert the back plate. If the pipe is 3/8" in diameter, the small groove of the back plate must rest against the pipe. If the pipe is 5/8" in diameter, the large groove must be facing the pipe.
- 4) While holding the valve in place, tighten the screw.
- 5) To pierce the pipe, turn the valve handle clockwise.
- 6) When the valve handle becomes firmly seated, the pipe has been pierced and the valve is closed.
- 7) With the saddle valve still closed, turn on the sink faucet and water supply.
- 8) After allowing the water to flush away debris from the installation, turn off the faucet and check the valve for leaks. Leave the valve closed at this time.

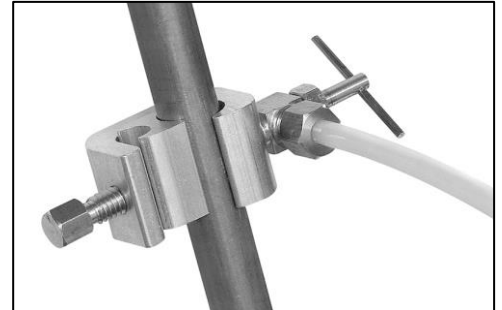

#### Installing on Hard Steel, Iron, Brass, or CPVC Pipe

- 1) Be sure the water supply is off.
- 2) Drill a 3/16" hole in the cold water supply line. A battery-powered drill should be used to avoid electric shock. Be extremely careful not to drill through the opposite wall of the pipe.
- 3) Turn the valve handle until the lance (sharp point) appears no more than 3/16" beyond the rubber gasket.
- 4) Place the lance over the hole so that it slides into the hole.
- 5) If the pipe is 3/8" in diameter, the small groove of the back plate must rest against the pipe. If the pipe is 5/8" in diameter, the large groove must be facing the pipe.
- 6) While holding the valve in place, tighten the brass screw.
- 7) Turn the valve handle clockwise until it is firmly seated and the valve is closed.
- 8) With the valve closed, turn on the sink faucet and water supply.
- 9) After allowing the water to flush away debris from the installation, turn off the faucet and check the valve for leaks. Leave the valve closed at this time.

### If Using Mur-lok® RO-Pal Connector (Optional)



The Mur-lok® RO-Pal Feed Water Connector is a reliable choice for rigid piping. It works great with copper, chrome, CPVS, and PEX tubing. Easy installation in five minutes or less, and has an all plastic design to eliminate corrosion.

- 1) Be sure the water supply is off.
- 2) Ensure the pipe or tubing is RIGID.
- 3) Identify a smooth, even surface, and cut a section of pipe where the RO-Pal will be installed.
- 4) Remove all burrs from pipe using a sandcloth.  
**IMPORTANT:** Do not use any sealants or Teflon tape on any of the RO-Pal's fittings.
- 5) Slide narrow end of nut onto pipe, inside threaded end facing tee.
- 6) Slide flat side of grab ring toward nut.
- 7) Push wide end of cone toward grab ring. Make sure narrow portion of cone has 1/4" to 1/2" of pipe exposed. If cone slides on with difficulty, apply a SMALL amount of DOW III Silicone Lubricant to the end of the pipe.
- 8) Slide nut and grab ring towards cone and hand tighten onto tee.
- 9) Turn nut by hand until tight. Additionally, tighten nut with wrench 1 to 1-1/2 complete turns. Be sure not to over tighten.
- 10) Install other nut in same manner as steps 4 through 9.
- 11) Leave the valve closed at this time.

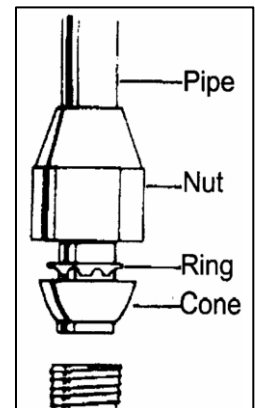

## Step 4: Install the Drain Saddle Clamp

Drain saddle clamps are used to direct the reject water of a RO System to drain. The provided drain saddle clamp is designed for a standard 1-1/2" OD drainpipe. Always inspect the condition of drainpipes before install and ensure they are not thin and frail. Drain saddle valve should not be installed near the garbage disposal; installation must be on the opposite pipe and above the cross bar pipe.

**IMPORTANT:** Drain saddle clamps are available with 1/4" and 3/8" tubing connections. Most air gap faucets require a 3/8" drain connection, while non-air gap faucet systems use a 1/4" drain connection. Identify your drain lines and confirm that your drain saddle clamp has the appropriate connection size.

**IMPORTANT:** For basement installations, drain saddle clamps may not be needed. Please see the **APPENDIX** at the end of this section for additional information.

**CAUTION:** Never install the drain saddle valve near the garbage disposal drainpipe. Backpressure caused by either unit may back water up into the system.

- 1) Place the small square black felt gasket, with a circle cut out of the middle, on the inside of the drain saddle. Peel off the sticky tape backing and adhere it to the inside of the drain saddle.
- 2) Position the drain saddle around the drain pipe at least 1-1/2" above the nut of the P-trap, to allow for the removal of the P-trap if necessary. Once in position, securely tighten the saddle clamp to the drainpipe.
- 3) Insert a 1/4" drill bit into the opening of the drain saddle and drill a hole in the drainpipe. Be extremely careful not to drill through the other side of the pipe.
- 4) Attach the black compression nut to the drain saddle, but do not tighten at this time.

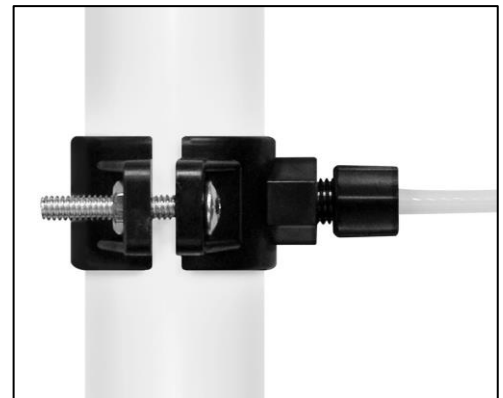

## Step 5: Install the Tank Shut-Off Valve

Locate the John Guest® tank shut-off valve included in the Parts Packet shipped with your system.

- 1) Wrap the male pipe threads (clockwise direction) on the top of the tank with Teflon tape.
- 2) Hand-tighten the tank shut-off valve to the top of the tank. Be sure it is tight, but do not over-tighten.
- 3) Turn the tank valve to the closed position for now.
- 4) For optimal flow, position the tank within 10 feet of the faucet.
- 5) Check the storage tank pre-charge pressure at the stem near the bottom of the tank. Tank pressure, when empty, should be 5 to 7 psi.

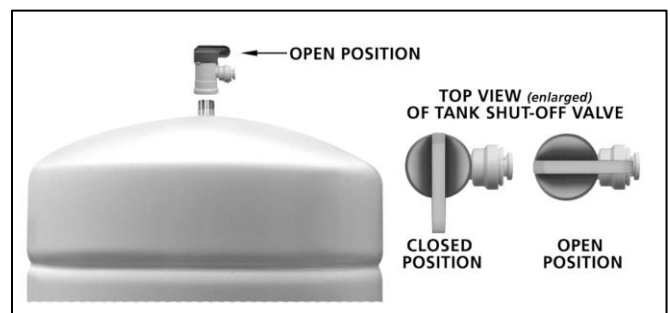



## Step 6: Install the RO Membrane

While some models may have the RO membrane pre-installed, it's important to verify this to ensure proper system function.

- 1) Carefully un-snap the white horizontal membrane vessel from the clips mounted on the metal bracket.
- 2) Disconnect the tubing from the fitting on the threaded end cap of the vessel. To remove the tubing:
  - a. John Guest Fitting – push the collet against the fitting and pull on the tubing at the same time.
  - b. Jaco Fitting – unscrew the compression nut until tubing pulls out.
- 3) Remove the end cap by turning counter clockwise to loosen.
- 4) Remove the new RO membrane from the plastic bag. Note: If included and not already installed, flow restrictor may be in a separate bag and taped to outside of the membrane bag; set aside flow restrictor for later installation – do not discard.
- 5) Lubricate the o-rings on the product water tube and the brine seal with a clean coating of food grade silicone, or water-soluble lubricant, canola oil, or vegetable oil. **DO NOT** use petroleum-based lubricants, such as Vaseline.
- 6) Gently glide the membrane (o-ring end first) into the membrane vessel.

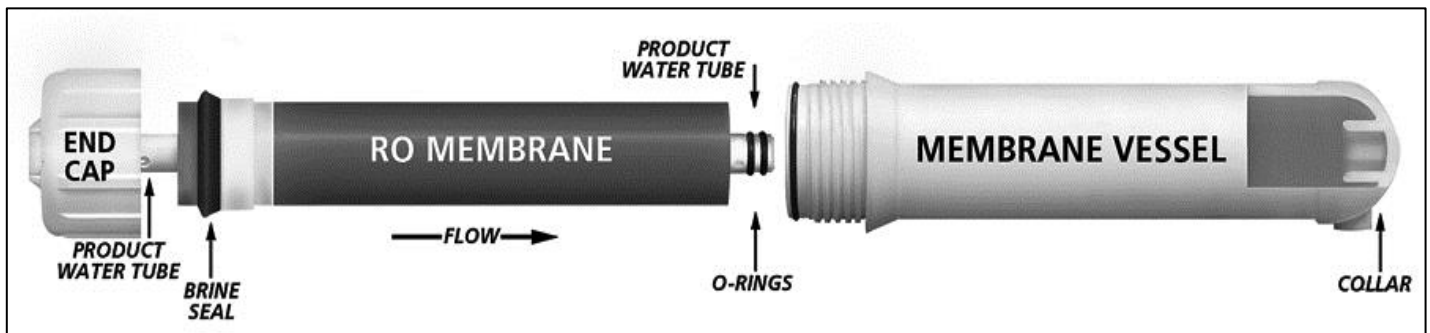

- 7) Once the membrane has been inserted into the vessel, you must take your thumb and firmly push to properly seat the membrane. To be properly seated, the end of the product water tube must be pressed all the way against the end of the vessel, as shown in the diagram below:

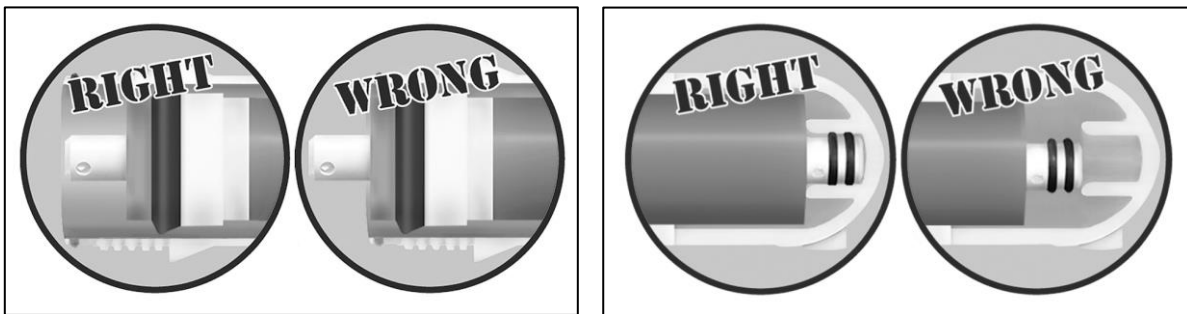

- 8) Turn the end cap back onto vessel and reconnect the tubing. Snap the membrane vessel back into the plastic clips.

## Step 7: Install the Filter Cartridges

While some models may have filter cartridges pre-installed, it's important to verify this in order to prevent permanent damage to RO membrane upon start-up.

- 1) Using the filter-housing wrench provided with the RO System, unscrew the filter housing sumps.
- 2) If not already installed, please remove the filter cartridges from their packaging, and insert the filter cartridges into their appropriate housing sump.

**IMPORTANT:** Your RO System may be suitable for a variety of filter cartridges. Always ensure that the appropriate filters are installed for proper pre-filtration.

- 3) Make sure that they slip down over the standpipe in the bottom of the filter housing sumps.
- 4) Verify that the o-ring is properly seated in the groove of the housing sump.
- 5) Turn the sumps, with the cartridges inside, back onto the appropriate cap – designated by the corresponding label. Firmly tighten, but do not over tighten.



## Step 8: Mount RO System

The mounting bracket of the RO System, has pre-drilled slots for easy mounting. Depending on the location chosen, additional support may be needed to provide a firm and solid mounting of the system. To allow for future system maintenance, ensure there's at least 4" from the floor.

**IMPORTANT:** For basement installations, please see the **APPENDIX** at the end of this section for additional information.

- 1) Using the bracket as a template, mark the mounting screw locations.
- 2) Drill 1/8" holes at each mark.
- 3) Install the screws and tighten them until the heads are about 1/8" from the wall
- 4) Hang the RO System on the mounting screws and hand-tighten up against the wall.
- 5) Keep the system in place while making the tubing connections.

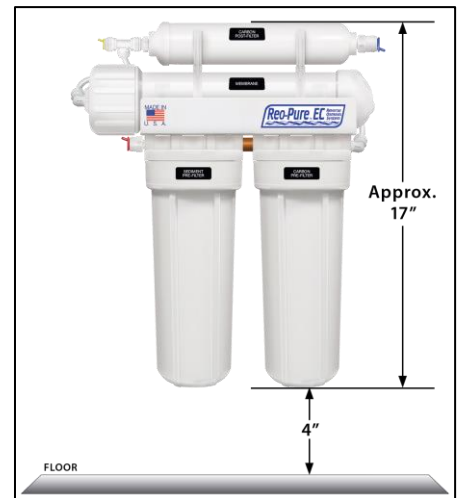

## Step 9: Make Tubing Connections

Complete all prior steps before making the tubing connections. The RO System has colored plugs inserted into the fittings for easy identification of the system connections. **Please reference "Getting to Know Your System" and "Flow Diagram" in an earlier section to more easily identify the correct placement of tubing.**

**IMPORTANT:** For basement installations, please see the **APPENDIX** at the end of this section for additional information.

*When making tubing connections, follow these helpful tips:*

- Attempt to keep tubing lines long enough to service the system later.
- Do not cut tubing at an angle. Cuts should be perfectly square.
- Insert tubing until it seats against stop inside of fitting. See "How to Make a Proper Quick Connect Tubing Connection" for more information.
- Only remove colored plugs from the fitting when you are ready to make the connection. Make one connection at a time, removing the colored plugs as you go.

### **Feed Water Connection (RED Plug)**

- 1) Go back to the feed water valve you chose to install on the cold water supply line.
- 2) Using the coil of RED 1/4" tubing provided with the Parts Packet, connect one end into the feed water valve. Ensure connection is secure.  
**NOTE:** If connection uses a compression nut, it's recommended to use a 1/4" tube insert. The insert is pushed into the end of the tubing, which supports it from collapsing.
- 3) Locate the **Feed Water Inlet** on your RO System. This should be identified with a 1/4" RED plug.

- 4) Remove the RED plug from the RO System, and connect the other end of the 1/4" RED tubing into the fitting. Ensure connection is secure.

**NOTE:** For basement installations, a longer length of feed water tubing may be needed.

#### **Storage Tank Water Connection (YELLOW Plug)**

- 1) Locate the **Storage Tank Outlet**, found on the side of the system. This should be identified with a 3/8" YELLOW plug.
- 2) Using the coil of 3/8" YELLOW tubing provided with the Parts Packet, remove the YELLOW plug and insert one end of the tubing into the fitting. Ensure connection is secure.
- 3) Locate the **Tank Shut-Off Valve** that you installed in an earlier step. Connect the other end of the 3/8" YELLOW tubing to this shut-off valve. Ensure the connection is secure.

#### **Faucet Connection (BLUE Plug)**

- 1) Locate the **Faucet Outlet** on your RO System. This should be identified with a 3/8" BLUE plug.
- 2) Using the coil of 3/8" BLUE tubing provided with the Parts Packet, remove the BLUE plug from the RO System, and connect one end of the tubing into the fitting. Ensure connection is secure.
- 3) Locate the **Faucet Connector** that was attached to the faucet stem in an earlier step. Connect the other end of 3/8" BLUE tubing to this fitting. Ensure connection is secure.

**IMPORTANT:** The product water of any RO System should not flow through copper pipe, as the purity of the water will leach copper into the water. This may cause an unpleasant taste in the water, and may also result in pinholes to form inside the pipe.

#### **Drain/Reject Water Connection (BLACK plug)**

For a RO System to function properly there must be a certain amount of backpressure on the drain/reject line. A drain line flow restrictor is installed for this purpose. If drain line flow restrictor is missing, water will continually run to drain.

### **IMPORTANT**

**AN INTERNAL, CAPILLARY FLOW RESTRICTOR MUST BE INSTALLED WITH EVERY RO SYSTEM.**

It is extremely important that the flow restrictor be installed correctly on the drain line tube.

*See below diagram for location of flow restrictor.*

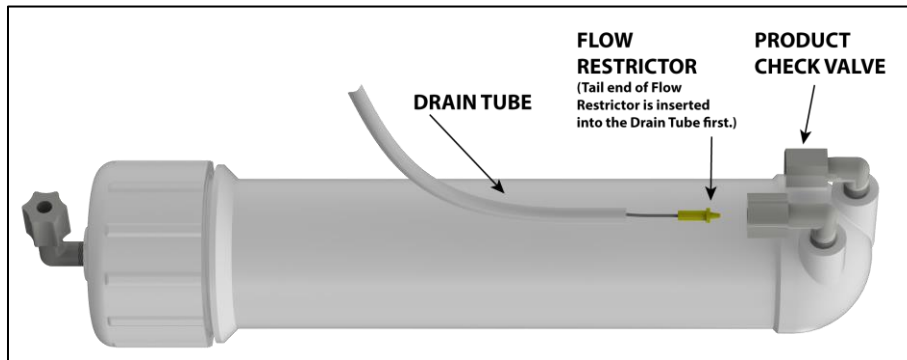

Connect Drain Line Tubing:

- 1) Locate the **Drain/Reject Outlet** on your RO System. This should be identified with a 1/4" BLACK plug.
- 2) Using the coil of 1/4" BLACK tubing provided with the Parts Packet, remove the BLACK plug, and insert tubing into the **Drain/Reject Outlet** of the RO System. Ensure connection is secure.

The remaining drain/reject connection instructions will vary depending on whether you have an air gap faucet or a non-air gap faucet. Please only follow the steps that correspond to your type of faucet:

#### *For a Standard Air Gap Faucet*

- 1) At this point, one end of the provided 1/4" BLACK tubing should be connected to the **Drain/Reject Outlet** on your RO System, with the desired Drain Flow Restrictor installed.
- 2) Connect the other end of the 1/4" BLACK tubing to the 1/4" barb connector, found at the bottom of the air gap faucet. Ensure connection is secure.

- 3) Using the coil of 3/8" BLACK tubing provided with the Parts Packet, connect one end to the 3/8" barb connection, found at the bottom of the air gap faucet. Ensure connection is secure.
- 4) Locate the **Drain Saddle Clamp** (installed in a previous step) and unscrew the attached compression nut.
- 5) Slip the compression nut over the second end of the 3/8" BLACK tubing – making sure threads are facing the correct direction.
- 6) Find the 3/8" tube insert that was enclosed with the Parts Packet. Place this insert inside the second end of the 3/8" BLACK tubing.
- 7) Push the 3/8" BLACK tubing with insert into the **Drain Saddle Clamp** and tighten with wrench until tight. Ensure connection is secure.

**NOTE:** When connecting the drain tubing, make a downward slope from the RO System to the drain saddle to allow for proper drainage. Avoid bending or kinking the drain tubing.

*For a Standard Non-Air Gap Faucet*

- 1) At this point, one end of the provided 1/4" BLACK tubing should be connected to the **Drain/Reject Outlet** on your RO System, with the desired Drain Flow Restrictor installed.
- 2) Locate the **Drain Saddle Clamp** (installed in a previous step) and unscrew the attached compression nut.
- 3) Slip the compression nut over the second end of the 1/4" BLACK tubing – making sure threads are facing the correct direction.
- 4) Find the 1/4" tube insert that was enclosed with the Parts Packet. Place this insert inside the second end of the 1/4" BLACK tubing.
- 5) Push the 1/4" BLACK tubing with insert into the **Drain Saddle Clamp** and tighten with wrench until tight. Ensure connection is secure.

**NOTE:** When connecting the drain tubing, make a downward slope from the RO System to the drain to allow for proper drainage. Avoid bending or kinking the drain tubing.

## Step 10: Ice Maker Connection (Optional)

This RO System has been designed to easily connect to any standard refrigerator ice maker or ice maker/water dispenser. If you choose to connect your RO System to an ice maker, you will need additional hardware. It's recommended to use the following:

- ✓ FDA Approved, NSF, LLDPE Tubing – 25' of 1/4"
- ✓ Reducing Tee – 3/8" (end) x 3/8" (end) x 1/4" (branch)
- ✓ Shutoff Valve 1/4" x 1/4"

**TIP:** If ice maker connection is being installed after the start-up of your RO System, any water in the system should be closed off. It's advised to close the feed water supply to your RO System, close the storage tank shut-off valve, open the dispenser faucet, and allow water to drain. A bucket should also be handy to catch any residual water when the product line is cut in the succeeding steps.

- 1) Locate the 3/8" BLUE tubing that runs from the **Faucet Outlet** to the dispenser faucet.
- 2) Using a tubing cutter, squarely cut tubing in a location that's most convenient to branch off. Cut should be at least 5-10" past the point at which it comes out of your RO System. Allow any water that may be in the line to drain into bucket.
- 3) Using a reducing tee, 3/8" (end) x 3/8" (end) x 1/4" (branch), connect each end of the 3/8" BLUE tubing to the 3/8" connections on the reducing tee.
- 4) Connect one end of 15' of 1/4" tubing into the 1/4" branch of the reducing tee. Ensure all connections are secure.
- 5) 5-10" down the 15' tubing, cut it and connect an inline shutoff valve to each end.

**IMPORTANT:** This inline shutoff valve will allow you to shut off the water to your ice maker for future servicing and maintenance. Its installation is required.

- 6) Connect the remaining end of the 15' tubing to your ice maker.

**NOTE:** Shut-off valve to ice maker should always be closed during routine servicing, maintenance, and sanitization. Only open the shutoff valve when finished, and when RO System has been thoroughly flushed. This will prevent unwanted chemicals or particulates from entering the ice machine.

## Step 11: Record Information in a System Maintenance & Repair Log

To ensure proper care and maintenance of your RO System, now is the time to begin a log, specifying the date of installation and the test results obtained at the original start-up. Additional data should be kept with dates and details of maintenance performed, along with test results at that time. Thorough records of any changes in system performance are important to have, should a problem ever arise.

## APPENDIX: Basement Installations

Installing a RO System in the basement will result in some alternative installation instructions. This appendix is provided to complement the Installation Instructions in the previous section. Please read this appendix carefully, in addition to the installation instructions provided previously. The following are variations generally required for basement installations:

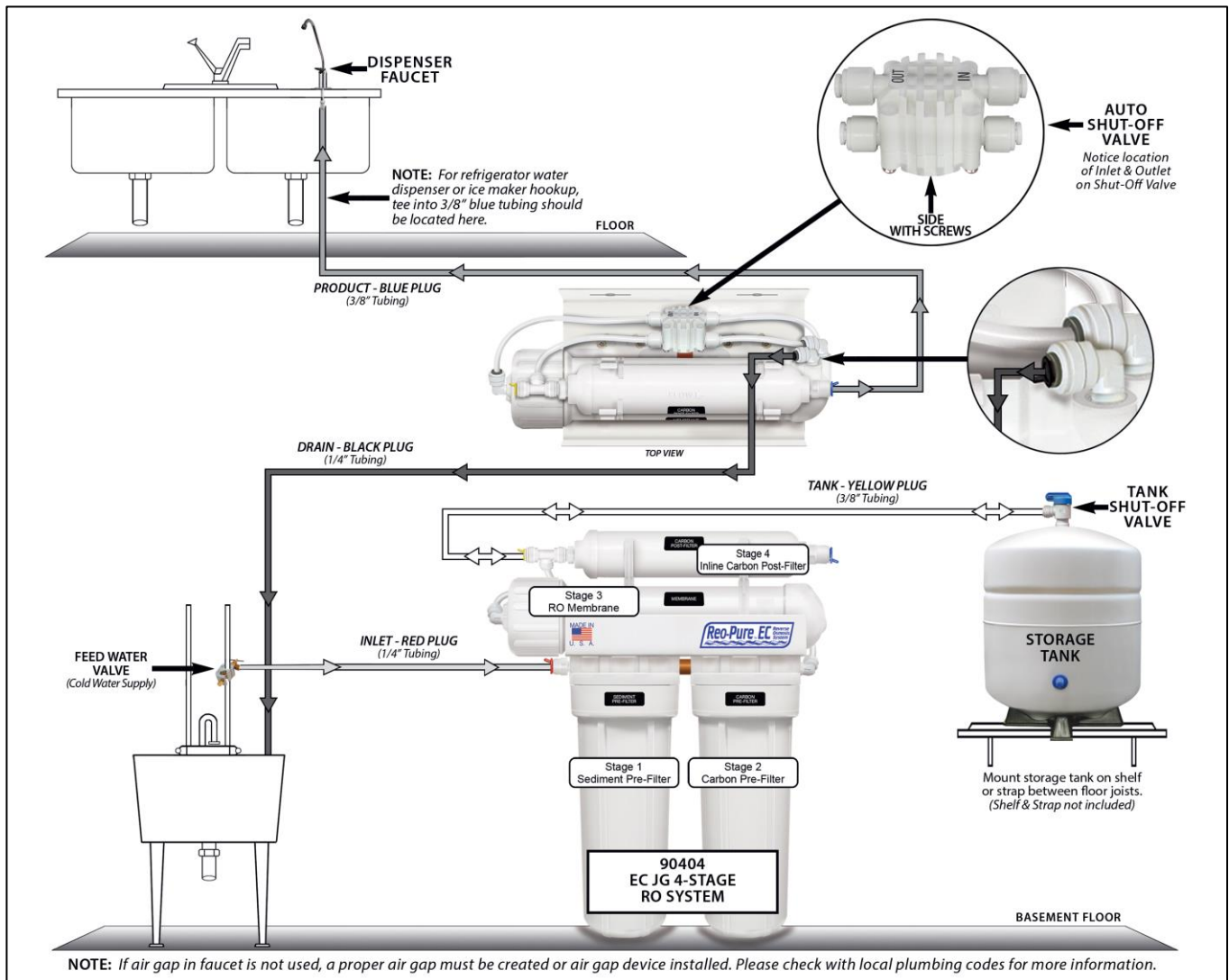

### Faucet Installation

In basement installations, it's common to have your air gap located in the basement as well. Therefore, a specialized air gap dispenser faucet is generally not needed. A standard non-air gap faucet may be all you need, which requires a smaller (9/16") hole in the kitchen sink or countertop. An air gap faucet may still be used with basement installations, but it's recommended to not hook up any air gap tubing to the faucet since an alternative air gap will be used elsewhere in the drain line.

### Install the Drain Saddle Clamp

For basement installations, the drain saddle is generally not used. Instead, the RO drain line is routed so that it drains into a laundry sink, floor drain, or standpipe through an approved air gap. An air gap of 1" is common in most cases, but a special air gap device may be used instead. Always check with local and state codes for applicable laws and regulations.

### Mount RO System

The RO System is generally mounted to the basement wall (using wall anchors) or to wood ceiling supports. To mount the RO System, keep bracket level and mark the location of the mounting holes. Install wall anchors and/or mounting screws as required. Leave screw heads protruding to allow the bracket's mounting holes to hook over them.

The storage tank may be oriented either vertically or horizontally and can be placed on a shelf, on the floor, or suspended from the ceiling supports using sturdy brackets. An effort should be made to minimize the distance between the tank and RO System to ensure proper flow to the faucet.

**IMPORTANT:** Always take caution and care when mounting equipment. Anticipate the weight of the system when full with water, and never install the RO System and its components in a way that creates a hazard. Special mounting brackets and hardware may be necessary for a secure and proper installation.

### ***Make Tubing Connections***

It's very common to require more tubing than was provided with your Parts Packet. However, an effort should be made to minimize the length of tubing as much as possible, while avoiding any loops, bends, and unnecessary lengths. Long connections will inhibit the performance of your RO System, and may affect its overall performance. A deliver pump may be needed to assist output to dispenser systems.

Product Water Connection (BLUE Plug): In connecting the 3/8" BLUE tubing from the **Faucet Outlet** of your RO System to an upstairs dispenser faucet, tubing must be routed through the floor to the vicinity of the RO System.

Drain/Reject Water Connection (BLACK plug): Once your drain flow restrictor and 1/4" BLACK tubing are connected to your RO System, route the opposite end to an appropriate drain connection (e.g. laundry sink, floor drain, stand pipe, etc.). Most local and state codes require an air gap between the outlet and the drain connection. A specialized air gap device may also be used. Ensure drain line is secured to avoid it from accidentally moving. Always check with local and state codes for applicable laws and regulations.

## Section 7: Start-Up Procedure

With the sediment/carbon pre-filter cartridges installed, and all tubing and tank connections in place, your RO System is ready for start-up! During start-up, it's crucial to thoroughly flush the system before the water is ready for consumption. Please follow these steps closely to ensure a proper start-up:

- 1) Slowly open the feed water shut-off valve that you installed on the cold water supply line.
- 2) Check the system carefully for any initial leaks.
- 3) Open the water storage tank shut-off valve.
- 4) Open the dispenser faucet. The RO System should now begin making water.
- 5) Close the dispenser faucet as soon as water begins to flow and do not open again until the storage tank is full. Check the system for leaks once again.
- 6) After the tank is full (you will hear the water stop), open the dispenser faucet and completely drain the tank and RO System.
- 7) When the faucet is first opened, expect air and carbon fines (very fine black powder) from the carbon filters to be rinsed out. This is completely normal for the first tank of water or after carbon filters are changed.
- 8) After the system has been drained, close the faucet and repeat this flush cycle two more times. DO NOT DRINK THE WATER UNTIL THE TANK AND SYSTEM HAVE BEEN FLUSHED AT LEAST THREE TIMES.
- 9) Test the product water at this time to ensure that the system is operating properly.
- 10) The RO System is now ready for use!

You may notice that the water is milky colored during the first week. It is due to the air bubbles in the water. It is normal and safe.

**IMPORTANT:** This RO System contains replaceable treatment components critical for effective performance. Replacement of the system components should be done with one of identical specifications, in order to attain the same efficiency and contaminant reduction as originally designed. It is the user's responsibility to periodically test the product water to verify the system is performing satisfactorily.

We recommend opening the dispenser faucet for at least 10 seconds prior to using the water. This is especially important if the RO water is not used daily. After periods of non-use, such as a week of vacation, it is better to empty the storage tank and allow the system to produce fresh water for use. If the RO System is not used for 3 to 4 weeks, we recommend you sanitize the system and change the filter cartridges. Longer periods of non-use may require additional service from a water treatment professional in your area.

**Check for leaks daily for the first week, and periodically thereafter.**



## Section 8: Maintenance Procedures

### Filter Cartridge and RO Membrane Replacement

This RO System contains filter cartridges that must be replaced regularly to maintain proper performance. The recommended schedule for changing the filter cartridges (not the RO membrane) is every 3 to 6 months, depending on the quantity of water used and the feed water conditions.

The typical RO membrane life expectancy (assuming adequate filter changes are done) is two to four years. The life of the RO membrane also depends greatly on the incoming water conditions and the amount of water used. Normally, replacement of the RO membrane is necessary whenever the product water begins to take on a different and objectionable taste, if there is a noticeable reduction in the amount of product water (after replacing the filter cartridges), or a change in the TDS level of the product water.

### Replacing Filter Cartridges

- 1) Use a drip pan or bucket to catch any water that may spill when the filter housing sumps are removed.
- 2) Close the shut-off valve installed on the cold water supply of feed line.
- 3) Close the shut-off valve installed on the storage tank.
- 4) Close any additional dispensing lines, such as an ice-maker (also turn off the ice maker).
- 5) Open the dispenser faucet to allow residual water in the system and its lines to empty. Leave the faucet open.
- 6) Using the spanner wrench supplied with your system, remove the filter housing sumps. Use one hand to hold the system and the other hand to turn the wrench clockwise to open. Any residual water inside sumps can be poured out.
- 7) Remove the used cartridges and discard.

**IMPORTANT:** Take careful note of which filter cartridges you removed from each sump. It's important for the filter cartridges to be replaced correctly. Please reference the "Getting to Know Your System" section for more information.

- 8) Wash the inside of the sumps using a mild detergent and soft cloth. Do not use abrasive cleaners or pads. Thoroughly rinse all the soap from the sumps.
- 9) Remove the o-ring from each sump and wipe the groove and o-ring clean. Lubricate the o-ring with a clean coating of food grade silicone, or water-soluble lubricant, such as glycerin, canola oil, or vegetable oil. DO NOT use petroleum-based lubricants, such as Vaseline.
- 10) Place the o-ring back in the groove and press it in with two fingers. It's important to make sure that the o-ring is seated properly. If the o-ring appears damaged or crimped, it should be replaced.
- 11) Remove the new filter cartridges from their wrapper.
- 12) Insert each filter into the corresponding housing sump, paying careful attention to the system labels. Labels will indicate the proper replacement of filters. Please reference the "Getting to Know Your System" diagram at the beginning of this manual for more information.
- 13) Make sure that the filters slip down over the standpipe in the bottom of the filter housing sump.
- 14) Turn the sumps, with the cartridges inside, back onto the housing cap. Firmly tighten, but do not over tighten.
- 15) Flush the system as follows:
  - a. Be sure the storage tank valve is still closed.
  - b. Slowly open the feed water saddle valve on the inlet water line. Check the system carefully for any leaks.
  - c. Water should begin flowing through the already open dispenser faucet. Allow water to flush until clear. This may take 5-10 minutes.

**NOTE:** When the faucet is first opened, expect air and carbon fines (very fine black powder) from the carbon filters to be rinsed out. This is normal after carbon filter changes.

**IMPORTANT:** Do not drink the water until the system and new filters have been thoroughly flushed.



- 16) Test the product water at this time to ensure that the system is operating properly.
- 17) Storage tank valve can now be opened at this time, along with any other dispensing lines.
- 18) The RO System is now ready for use.

**IMPORTANT:** To prevent costly repairs or possible water damage, housings should be replaced every 5 years. Be sure to date any new housings for future reference and indicate the next recommended replacement date.

### Changing the RO Membrane

Although changing the RO membrane is optional when replacing filter cartridges, it is important to replace filter cartridges whenever replacing the membrane.

- 1) Carefully remove the membrane vessel from the plastic clips mounting it to the metal bracket.
- 2) Carefully un-snap the white horizontal membrane vessel from the clips mounted on the metal bracket.
- 3) Disconnect the tubing from the fitting on the threaded end cap of the vessel. To remove the tubing:
  - a. John Guest Fitting – push the collet against the fitting and pull on the tubing at the same time.
  - b. Jaco Fitting – unscrew the compression nut until tubing pulls out.
- 4) Remove the end cap by turning counter clockwise to loosen.
- 5) With needle nose pliers, grip the product water tube of the RO membrane and pull to remove. Discard the used membrane.
- 6) Inspect the o-rings of the vessel for damage or crimp marks, and replace if necessary.
- 7) Rinse out the membrane vessel with a mild detergent and soft cloth.

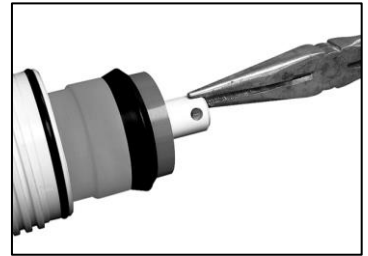

**NOTE:** If you wish to sanitize your RO system, now is an ideal time – while the RO membrane is out. If sanitizing, turn the end cap back onto the vessel (leaving the vessel empty at this time) and reconnect the tubing. Snap the membrane vessel back onto the plastic clips. Now refer to the section on how to Sanitize the RO System and Storage Tank, and continue with.

- 8) Remove the new RO membrane from the plastic bag.
- 9) Lubricate the o-rings on the product water tube and the brine seal with a clean coating of food grade silicone, or water-soluble lubricant, canola oil, or vegetable oil. DO NOT use petroleum-based lubricants, such as Vaseline.
- 10) Gently glide the membrane (o-ring end first) into the membrane vessel.

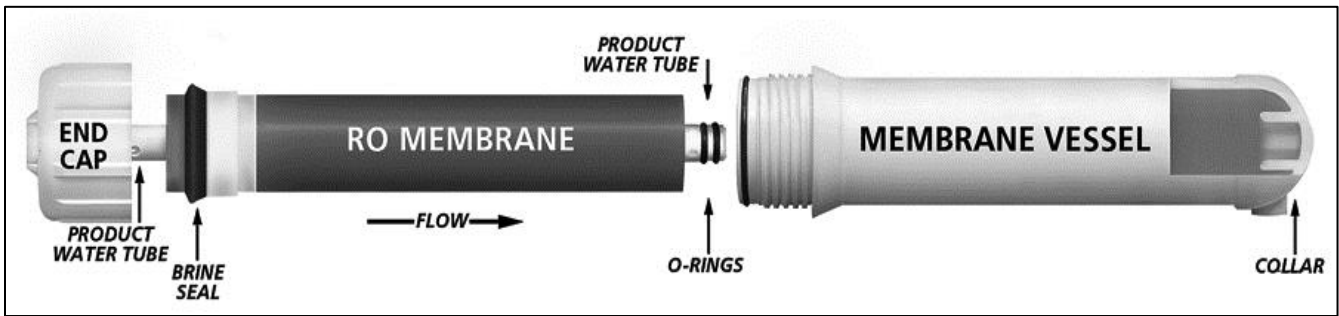

- 11) Once the membrane has been inserted into the vessel, you must take your thumb and firmly push to properly seat the membrane. To be properly seated, the end of the product water tube must be pressed all the way against the end of the vessel, as shown in the diagram below:

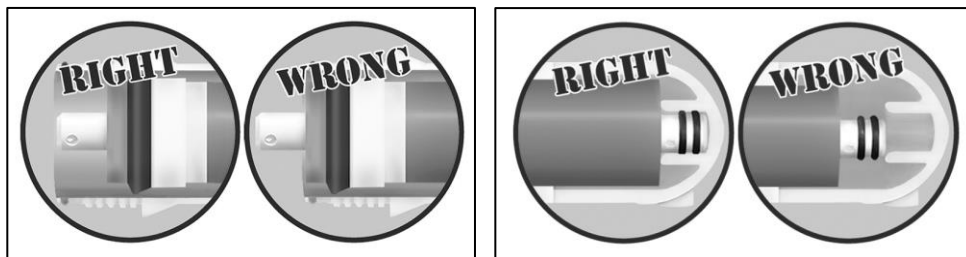

- 12) Turn the end cap back onto vessel (leave the vessel empty at this time) and reconnect the tubing. Snap the membrane vessel back into the plastic clips.

## Sanitize the RO System and Storage Tank

Sanitizing the RO System is optional with filter cartridge replacement, but required annually. This procedure is not intended to be effective in sanitizing highly contaminated systems which have been exposed to an excessive amount of bacteria, or systems which have developed foul smelling RO membranes or filters. Such systems require extensive cleaning and sanitizing. Consult your dealer for further information.

- 1) Close the shut-off valve installed on the cold water supply of the feed line.
- 2) Close any shutoff valves to additional dispensing lines, such as an ice-maker (also turn off the ice maker).
- 3) Ensure the shut-off valve installed on the storage tank is open.
- 4) Open the dispenser faucet to allow water in the system and tank to empty.
- 5) Close the dispenser faucet when water stops flowing.
- 6) Using the spanner wrench supplied with your system, remove the filter housing sumps. Use one hand to hold the system and the other hand to turn the wrench clockwise to open. Any residual water inside sumps can be poured out.
- 7) Remove used filter cartridges from the RO System and discard. Leaving them in during the sanitizing process may cause permanent damage and/or prevent proper sanitization.
- 8) Thoroughly rinse out each sump and fill about 1/3 full with hot water and mild detergent. Rinse. Add about 2-3 tablespoons of good quality unscented liquid chlorine household bleach and scrub with soft-bristled brush or sponge.
- 9) Remove o-rings from sumps and wipe grooves and o-rings clean. Lubricate o-rings with a clean coating of silicone or glycerin. Do not use petroleum based lubricants, such as Vaseline. Place o-rings back in place and press o-rings down into groove with two fingers. Make sure o-rings are seated evenly in the grooves. Note: It's very important to ensure proper filter seal. If o-rings appear damaged or crimped, they should be replaced at this time.
- 10) Using a good quality unscented liquid chlorine household bleach. Pour approximately one teaspoon into each filter housing sump of your RO System.

**IMPORTANT:** Do not use more than the recommended amount of liquid chlorine household bleach. Doing so may cause permanent damage to the membrane.

- 11) Temporarily replace the housing sumps onto the filter housing caps, without any filter cartridges inside. Firmly tighten, but do not over tighten.
- 12) Slowly open the feed water valve and allow water to enter the system.
- 13) Open the dispenser faucet.
- 14) As soon as the sanitizing solution can be detected (by smell) from the dispenser faucet, turn the dispenser faucet closed.
- 15) Wait for the storage tank to fill with water (you will hear the water stop when full), and then close the feed water valve. Check the system for any leaks.
- 16) Do not open the dispensing faucet or feed water valve again for at least 6 hours.
- 17) After 6 hours, open the dispenser faucet and drain the system.
- 18) Once completely drained, filter cartridges can be returned to their appropriate filter housing sumps. Please reference the "Replacing Filter Cartridges" for additional information.
- 19) Flush the system as follows:
  - a. Be sure the storage tank valve is open.
  - b. Slowly open the feed water valve on the inlet water line. Check the system carefully for any leaks.
  - c. Open the dispenser faucet and completely drain the tank and RO System.
  - d. When the faucet is first opened, expect air to be flushed out. If filter cartridges were also replaced, there may be carbon fines (very fine black powder) being rinsed out too. This is normal after carbon filter changes.
  - e. After the system has been completely drained, close the faucet, wait for tank to fill and the RO system to turn off; repeat this flush cycle two more times.

**IMPORTANT: DO NOT DRINK THE WATER UNTIL THE TANK AND SYSTEM HAVE BEEN FLUSHED AT LEAST THREE TIMES.**

- 20) Test the product water at this time to ensure that the system is operating properly.
- 21) The RO System is now ready for use, and any other dispensing lines (e.g. ice-makers) can now be opened at this time.

**IMPORTANT:** Periodically check all tubing lines for wear, discoloration, kinks, or cracks. Replace whenever in doubt to avoid leaks. This may also be a good time to consider replacing the drain line flow restrictor.



## Section 10: System Troubleshooting

PROBLEM	POSSIBLE CAUSE	SOLUTION
<b>Low Quantity of Product Water from Storage Tank</b>	Feed water saddle valve is plugged or clogged.	Open valve or unclog.
	Clogged sediment/carbon pre-filter.	Replace filters.
	Low water pressure.	Feed Water pressure must be above 40 psig.
	RO membrane is fouled.	See Feed Water operating limits. Correct cause of fouling, replace Membrane
	Plugged inline activated carbon post-filter.	Replace Post-Filter.
	Air pre-charge pressure in storage tank is too high.	Empty water from storage tank, and with the faucet open, adjust air pressure to 5–7 psig (35–48 kPa) range.
	Air pre-charge pressure in storage tank is too low.	
	Air bladder in storage tank is ruptured.	Replace storage tank.
	Storage tank valve is closed	Open valve.
	No drain flow; the drain flow restrictor is clogged.	Clear or replace
	The product water check valve is clogged.	Free check-valve or replace elbow fitting.
	The automatic shut-off valve is malfunctioning.	Replace automatic shut-off valve.
<b>Low Pressure at the Dispensing Faucet</b>	Carbon post-filter is plugged.	Replace post-filter.
	Air pre-charge in the storage tank is too low.	Empty water from storage tank and with the faucet open, adjust the air pressure to the 5-7 psig (35-48 kPa) range. Check for leakage at the air valve stem.
	Storage tank shut-off valve is partially closed.	Open valve.
	The dispensing faucet is out of adjustment or faulty.	Repair or replace dispensing faucet.
	Heavy water use, storage tank is depleted.	Allow storage tank to refill (adding a second storage tank will increase the storage capacity).
	Low water production.	See “Low Quantity of Product Water from Storage Tank” above.
	<b>High Total Dissolved Solids (TDS) in the Product Water</b>	Clogged sediment/carbon pre-filter.
Low Water Pressure.		Feed water pressure must be above 40 psig.
		Check feed water valve.
RO membrane is faulty.		Replace membrane.
RO membrane is expended.		If membrane life is unusually short, inspect further and replace membrane.
The product water and drain water lines are reversed.		See flow diagram and correct plumbing.
No drain flow, the drain orifice in the dispensing faucet is plugged.		Clear or replace dispensing faucet.
No drain flow, drain flow restrictor is clogged.		Clear or replace drain flow restrictor.
The automatic shut-off valve is not closing.		Repair or replace the automatic shut-off valve.
New inline or activated carbon pre-filter not rinsed completely.		Flush with several full tanks of product water.
The feed water TDS has increased.	An increase in feed water TDS will give corresponding increase in product water TDS.	

<b>Tastes and Odors in the Product Water</b>	The inline or activated carbon pre-filter is exhausted.	Replace filters.
	There is foreign matter in the storage tank.	Clean, flush and sanitize the system. Replace the filters.
	The product water and drain water lines are reversed.	See flow diagram and correct plumbing.
	Dissolved gasses in the feed water.	Pre-treat feed water to remove dissolved gasses.
	Increase in product water TDS.	See high "High TDS in the Product Water" section above.
<b>Drain Water Overflows at the Dispensing Faucet</b>	Air gap is blocked.	Clear Air Gap. Rinse with vinegar for removal of calcium buildup.
	Drain tubing is clogged.	Clear tubing.
	Drain clamp hole is misaligned.	Align the hole in the drainpipe.
	Excessive drain flow rate.	Replace drain flow restrictor.
<b>Faucet Leaks or Drips</b>	Leaks from base of the delivery tube.	O-ring is bad. replace o-ring.
<b>Fitting Leaks, in General.</b>	Close the Feed Water Saddle Valve and relieve pressure before disconnecting any tubing or replacing any fitting. Before replacing a fitting, re-cut the tubing and re-insert into the fitting to see if that solves the leak. If pipe threads are leaking, remove and re-tape with Teflon tape.	



## System Warranty

### One-Year Limited Warranty

#### Warranty Terms

Subject to the terms and conditions set forth hereinafter, Great Lakes International, Inc. (hereafter "Manufacturer") warrants to the original purchaser (hereafter the "Buyer") that the systems and products manufactured by the Manufacturer are free from defects in material and in workmanship for twelve (12) months from the Warranty Commencement Date (as defined below), only when used strictly in accordance with the applicable operating instructions and within the range of the operating conditions specified by the Manufacturer for each such product.

This Warranty does not extend to systems, equipment, or components manufactured by others, nor to systems, equipment, or components manufactured by others and distributed by the Manufacturer. This Warranty does not extend to equipment or components manufactured by others which have been incorporated into the Manufacturer's product but, if allowable, the Manufacturer hereby assigns, without warranty, to the Buyer's interest, if any, under any warranty made by the manufacturer of such equipment or component. This Warranty does not cover disposable items such as filters, fuses, o-rings, regeneration materials/chemicals, or other such disposable items, which must be replaced periodically under the normal and foreseeable operating conditions of the goods warranted hereby. This Warranty does not cover any equipment that is installed or used outside the United States of America and Canada.

#### Warranty Commencement Date

The Warranty Commencement Date for each Manufacturer product shall be the later of the date of: (1) receipt by the Buyer, or (2) the date of installation at the Buyer's premises provided that such installation must occur within three (3) months of shipment from the Manufacturer's manufacturing facility in Yorkville, Wisconsin. In no event shall the Warranty Commencement Date exceed three (3) months from the shipment from Manufacturer's manufacturing facility. The Buyer shall provide proof of purchase in order to exercise rights granted under this Warranty. If requested by the Manufacturer, the Buyer must also provide proof of the installation date.

#### Warranty Service

THE MANUFACTURER'S OBLIGATION UNDER THIS WARRANTY IS LIMITED TO THE REPAIR OR REPLACEMENT (AT THE MANUFACTURER'S SOLE DISCRETION) OF ANY PRODUCT, OR COMPONENT THEREOF, PROVED TO BE DEFECTIVE IN MATERIAL OR WORKMANSHIP WITHIN THE COVERED WARRANTY PERIOD.

The Buyer, at the Buyer's risk and expense, shall be responsible for returning such product or component, only after obtaining a Return Goods Authorization (RGA) number from the Manufacturer, arranging for freight prepaid, and in conformance with any special packaging and shipping instructions set forth on the operation documentation or RGA instructions, or as otherwise reasonably required, to the Manufacturer's address set forth below, together with (1) RGA number issued by the Manufacturer at Buyer's request; (2) proof of purchase and, if necessary, proof of installation date; (3) a Return Goods Authorization Form; (4) a description of the suspected defects; (5) the serial number of the Reo-Pure product alleged to be defective; and (6) a description of the type of water and pretreatment equipment which has been utilized in connection with the product, if any. The Manufacturer shall, in the Manufacturer's reasonable discretion, be the sole judge of whether a returned product or component is defective in material or workmanship. Required or replaced products or components shall be returned surface freight. In genuine emergency situations, the Manufacturer will (at the Manufacturer's sole discretion) forward replacement parts to Buyer without waiting for authorized return of the questionable part(s). In such cases, Buyer will issue a purchase order or other payment guarantee prior to shipment. If the returned part is found to have been misused or abused, or the defective part is not received by the Manufacturer within thirty (30) days; the Buyer will be invoiced for the replacement part(s) provided. If the Manufacturer chooses to replace the equipment, the Manufacturer may replace it with reconditioned equipment.

This Warranty does not cover or include labor and/or travel to the Buyer's premise or location or any other location. Charges of \$1000 per day plus associated travel expenses will be incurred by the Buyer in providing the Warranty Service at any location other than the Manufacturer's main headquarters; that is if the Manufacturer deems that the product is not covered by said Warranty. The Manufacturer reserves the right to precondition such travel to Buyer's premises upon prepayment of the Manufacturer's anticipated costs of attending such premises.

### **Voidability of Warranty**

This Warranty shall be void and unenforceable as to any Reo-Pure™ product which has been damaged by accident, mishandling, abuse or has been repaired, modified, altered, disassembled or otherwise tampered with by anyone other than the Manufacturer or an authorized Manufacturer service representative; or, if any replacement parts are not authorized by the Manufacturer have been used, or, the product has not been installed, operated and maintained in strict accordance and adherence with the operating documentation and manuals for such product. Any expressed warranty, or similar representation of performance set forth in the operation documentation for a product incorporated into the Manufacturer product shall be void and unenforceable unless the feed water requirements set forth in the operating documentation for such product are unequivocally and strictly adhered to.

### **Limitations and Exclusions**

Under no circumstances will the Manufacturer have any liability for the damage to a facility or property due to floods or leaks caused by or related to the Products provided hereunder, installation, service or otherwise. All water systems must be protected from water hammer, have required safety relief valves, vacuum breakers and leak detectors. Floors and walls must be sealed and sloped to adequate floor drains. In addition, the Buyer is responsible for meeting all federal, state, and local (and foreign, to the extent applicable) laws, rules, and regulations regarding the monitoring of supplied equipment.

THIS WARRANTY AND REMEDIES DESCRIBED HEREIN AND HEREINABOVE ARE EXCLUSIVE AND IN LIEU OF ANY AND ALL OTHER WARRANTY OR REMEDIES, EXPRESSED OR IMPLIED, INCLUDING WITHOUT LIMITATION, ANY IMPLIED WARRANTY OF MERCHANTABILITY OR FITNESS FOR A PARTICULAR PURPOSE. IN NO EVENT SHALL THE MANUFACTURER BE LIABLE FOR ANY CONSEQUENTIAL, INCIDENTAL OR OTHER SIMILAR TYPES OF DAMAGES, FOR DAMAGES FOR THE LOSS OF PRODUCTION OR PROFITS, OR INJURY TO PERSON OR PROPERTY. NO PERSON HAS ANY AUTHORITY TO BIND THE MANUFACTURER TO OTHER THAN WHAT IS SET FORTH ABOVE. THIS WARRANTY IS NOT ASSIGNABLE OR TRANSFERABLE.

THIS WARRANTY GIVES THE BUYER SPECIFIC LEGAL RIGHTS AND THE BUYER MAY ALSO HAVE OTHER RIGHTS WHICH VARY FROM JURISDICTION TO JURISDICTION. THE PARTIES RECOGNIZE AND AGREE, THAT IN ALL RESPECTS THE LAWS OF THE STATE OF WISCONSIN SHALL APPLY TO AND SHALL GOVERN ANY INTERPRETATION OR LEGAL SIGNIFICANCE OF THIS DOCUMENT.

NO WARRANTY OR OTHER LIABILITY OF THE MANUFACTURER TO BUYER UNDER THIS AGREEMENT OR OTHERWISE WILL IN ANY EVENT EXCEED THE COST OF REPLACEMENT OF THE APPLICABLE PRODUCT, PART, OR ACCESSORY THAT IS SUBJECT TO ANY BREACH OF THE MANUFACTURER'S WARRANTY. THE MANUFACTURER WILL NOT BE LIABLE FOR ANY DAMAGE TO ANY PROPERTY OF BUYER OR TO BUYER'S BUYERS FOR ANY CONSEQUENTIAL, INCIDENTAL, OR ECONOMIC LOSS OR COMMERCIAL DAMAGE WHATSOEVER. REMEDIES HEREIN PROVIDED ARE EXPRESSLY MADE THE SOLE AND EXCLUSIVE REMEDIES FOR BREACH OF ANY WARRANTY OR OTHER OBLIGATION HEREUNDER EXPRESS OR IMPLIED OR FROM THE OPERATION OF LAW.

**For more information about Reo-Pure™ Systems, please contact us at:**

**Address:** 5211 S. Colony Ave, Union Grove, WI 53182

**Phone:** (262) 634-2386

**Fax:** (262) 634-6259

**Email:** [sales@greatlakesintl.com](mailto:sales@greatlakesintl.com)

**Website:** [www.greatlakesintl.com](http://www.greatlakesintl.com)















## Replacement Parts List EC 4-Stage Models





RO MEMBRANES	
	#602025 Membrane, 25 GPD
	#602050 Membrane, 50 GPD
	#602100 Membrane, 100 GPD
	#602150 Membrane, 150 GPD

FILTER CARTRIDGES	
	#14815502 Sediment Filter, 5 Micron
	#149251010 Carbon Block Filter, 10 Micron
	#13515503 In-Line Carbon Filter



FILTER HOUSINGS	
	#22158125 Filter Housing, 10" Slim Line, 1/4" NPT
	#710205 Filter Housing Wrench
	#22151121 Filter Housing O-Ring

FEED WATER SUPPLY VALVES	
	#3175120 Feed Water Saddle Valve
	#445555 JG Angle Stop Valve, with Conversion Adapter For 3/8" or 1/2" M/F x 3/8" QC
	T-Link Ball Valve #4461030405 For 1/2" Pipe ID, 5/8" OD, 1/4" NPTF #4461430405 For 3/4" Pipe ID, 7/8" OD, 1/4" NPTF
	**Recommended for use with T-Link Valves** #4401082200 Male Conn., 1/4" NPTM x 1/4" JG

PRESSURE TANKS, TOP CONNECTION	
	#5800001 4.4 GAL, 1/4" NPTM, White #5800003 4.4 GAL, 1/4" NPTM, Blue #5800004 4.4 GAL, 1/4" NPTM, Black
	#44501222 Tank Shut-Off Valve, 1/4" NPT X 3/8" Tube

CAPILLARY FLOW RESTRICTORS	
	#49200180 Brown – 25 GPD #49200350 Yellow – 50 GPD #49200600 Blue – 100 GPD #49201000 White – 150 GPD

FAUCETS	
	Long Reach Style Faucet, No Air Gap #03002, Chrome Long Reach Style Faucet, Air Gap #03008, Chrome
	Luxury Euro Style Faucet, No Air Gap #030218 Chrome #030228 Brushed Nickel #03053 Oil Rubbed Bronze Luxury Euro Style Faucet, Air Gap #030219 Chrome #030229 Brushed Nickel #030539 Oil Rubbed Bronze
	Vase Style Faucet, No Air Gap #03057 Chrome #03058 Brushed Nickel #03064 Oil Rubbed Bronze Vase Style Faucet, Air Gap #03077 Chrome #03078 Brushed Nickel
	#4483212 Faucet Connector 3/8"

MISCELLANEOUS	
	#3170903 Auto Shut-Off Valve, JG QC
	Drain Saddle Clamp #03900252 1/4" Connection #03903751 3/8" Connection

OPTIONS & ACCESSORIES				
	#075063 Flowlok™ Leak Detector, Complete Kit	 #075020 Inline TDS Monitor Single Probe, SM-1	 #44001 Collet Release Tool For 1/4" & 3/8"	
	#075062 Flowlok™ Leak Tray Only	 #075046 Pocket TDS Tester		 #075055 LeakBlock Sensor Shutoff Valve, LBS-10 ↓ Fittings Sold Separately ↓ #44010823 JG Male Conn. 1/4" TUBE #44011223 JG Male Conn. 3/8" TUBE
	#075060 Flowlok™ Shutoff Valve Only	 #44002 Tube Cutter		
#075061 Flowlok™ Pad Replacement Only				